

Liquid ring vacuum pumps

in compact design



LEM 325, LEM 425

Pressure range: 33 to 1013 mbar
Suction volume flow: 100 to 470 m³/h

CONSTRUCTION TYPE

SIHI liquid ring vacuum pumps are displacement pumps of uncomplicated and robust construction with the following particular features:

- non-polluting due to nearly isothermal compression
- oil-free, as no lubrication in the working chamber
- handling of nearly all gases and vapours
- small quantities of entrained liquid can be handled
- easy maintenance and reliable operation
- low noise and nearly free from vibration
- wide choice of material, therefore applicable nearly everywhere
- shaft not contact with the medium
- protection against cavitation as standard
- incorporated dirt drain
- incorporated central drain
- no metallic contact of the rotating parts

The SIHI liquid ring vacuum pumps LEM are single-stage ones.

APPLICATION

Handling and exhausting of dry and humid gases; entrained liquid can be handled during normal duty. The pumps are applied in all fields where a pressure of 33 to 900 mbar must be created by robust vacuum pumps.

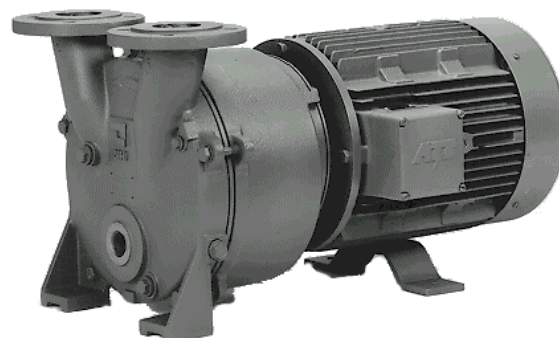

NOTE

During operation the pump must continuously be supplied with service liquid, normally water, in order to eliminate the heat resulting from the gas compression and to replenish the liquid ring, because part of the liquid is leaving the pump together with the gas. This liquid can be separated from the gas in a liquid separator (see catalogue part accessories).

It is possible to reuse the service liquid. The pumps are equipped with a device by which the contaminated service liquid can continuously be drained during operation (dirt drain), if necessary.

The direction of rotation is clockwise, when looking from the drive on the pump.

GENERAL TECHNICAL DATA

Pump type	unit	LEM 325	LEM 425
speed	50 Hz 60 Hz		1450 1750
Max. compression over pressure	bar		0,3 (0,5*)
Max. admissible pressure difference	bar		1,1 (1,5*)
Hydraulic test (over pressure)	bar		3
Moment of inertial of the rotating pump parts and of the water filling	kg · m ²	0,14	0,21
Sound pressure level at a suction pressure of 80 mbar	dB (A)	70	72
Max. gas temperature	dry °C saturated °C		200 100
Service liquid			
max. admissible temperature	°C		80
max. viscosity	mm ² /s		4
max. density	kg/m ³		1200
volume up to shaft level	liter	4,3	4,7
Max. flow resistance of the heat exchanger	bar		0,2

The combination of several limiting values is not admissible.

* In case of electric motors in 60 Hz design or protection type EEx e II T3

Material design

Item	COMPONENTS	MATERIAL DESIGN	
		0B	4B
10.10	Casing	0.6025	1.4408
10.90	Central body		
13.70	Guide disk		
23.50	Vane wheel impeller	0.7043	1.4517
43.30	Standard mechanical seal	Cr-steel / carbon/ Perbunan	Cr Ni Mo-steel / carbon / Viton
75.40	Valve balls	polyamide A	PTFE

Sectional drawing LEM 325, LEM 425

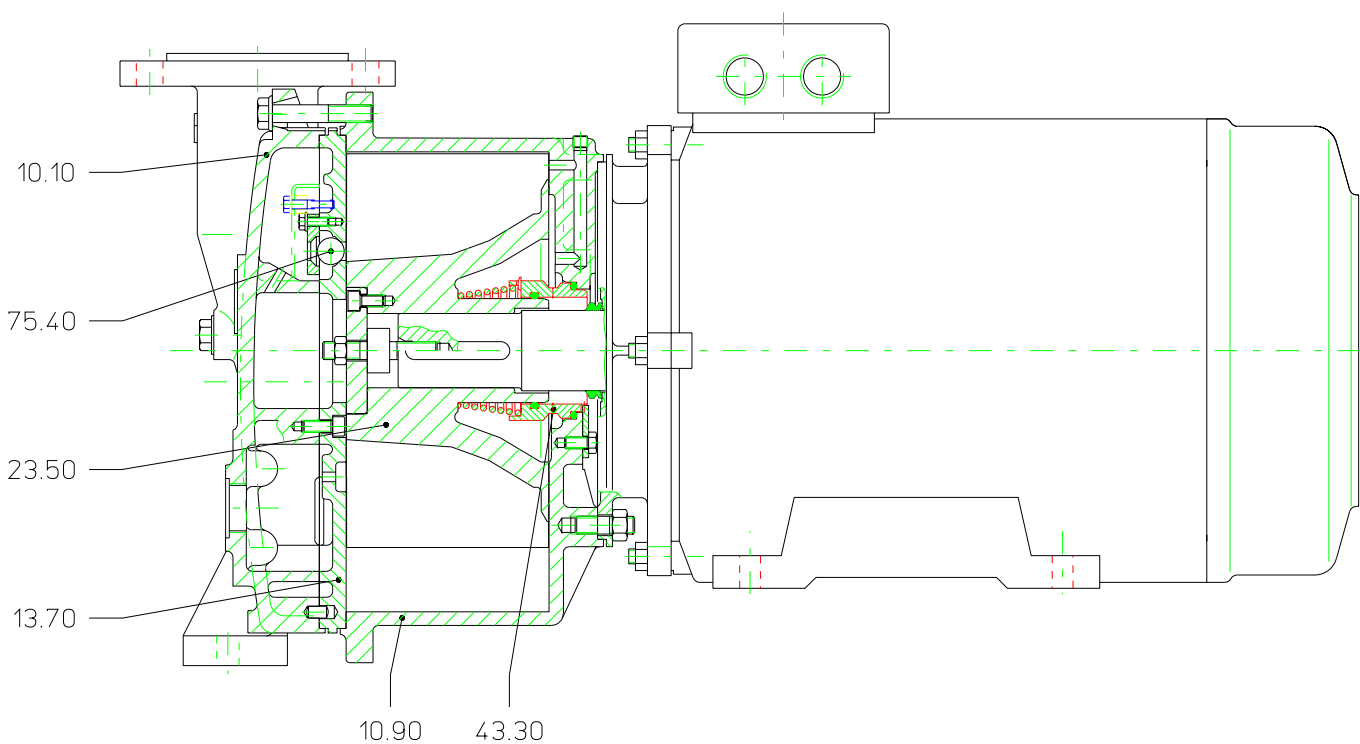

Fresh water requirements in [m³/h] dependent on suction pressure, speed, mode of operation and difference in temperature

suction pressure [mbar]		33					120					200					400				
pump	speed [rpm]	KB			FB	KB			FB	KB			FB	KB			FB				
		difference in temperature [°C]				difference in temperature [°C]				difference in temperature [°C]				difference in temperature [°C]							
		10	5	2		10	5	2		10	5	2		10	5	2					
LEM 325	1460	0,31	0,52	0,88	1,6	0,40	0,63	0,97	1,5	0,42	0,65	0,96	1,4	0,40	0,60	0,84	1,15				
	1750	0,42	0,67	1,03		0,50	0,75	1,07		0,52	0,76	1,05		0,49	0,69	0,91					
LEM 425	1460	0,46	0,74	1,19	2,0	0,56	0,85	1,23	1,75	0,57	0,84	1,18	1,6	0,45	0,60	0,75	0,9				
	1750	0,64	0,97	1,40		0,69	0,99	1,34		0,70	0,97	1,27		0,53	0,67	0,79					

FB = fresh liquid service

KB = combined liquid service with service water 10 °C, 5 °C, 2 °C warmer than the fresh water.

Suction volume flow and power absorption LEM 325

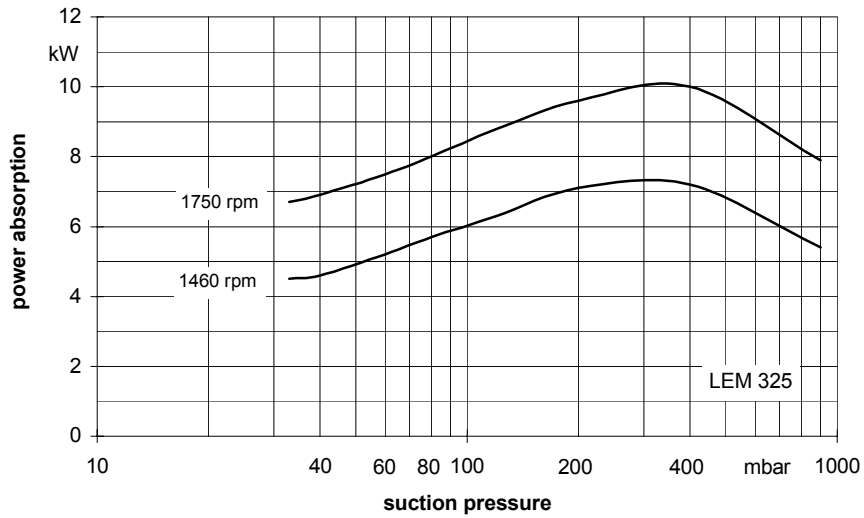
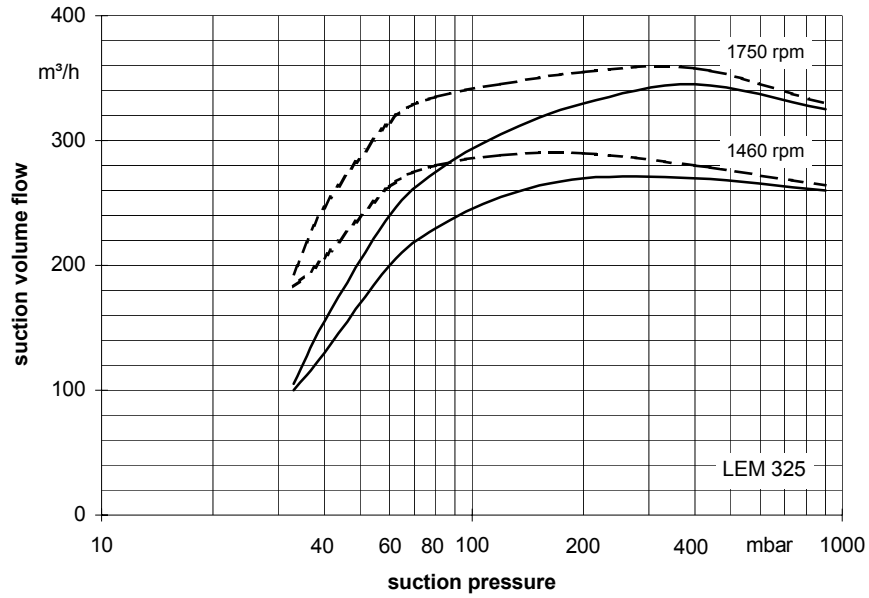

The operating data are applicable under the following conditions:

- pumping medium:
 - dry air: 20°C —————
 - water vapour saturated air: 20°C - - - - -
- service liquid:
 - water: 15°C

Compression pressure 1013 mbar (atmospheric pressure)

The suction volume flow is applied to the suction pressure

Tolerance of the operating data 10%

Max. fresh water need with lowest suction pressure

Suction volume flow and power absorption LEM 425

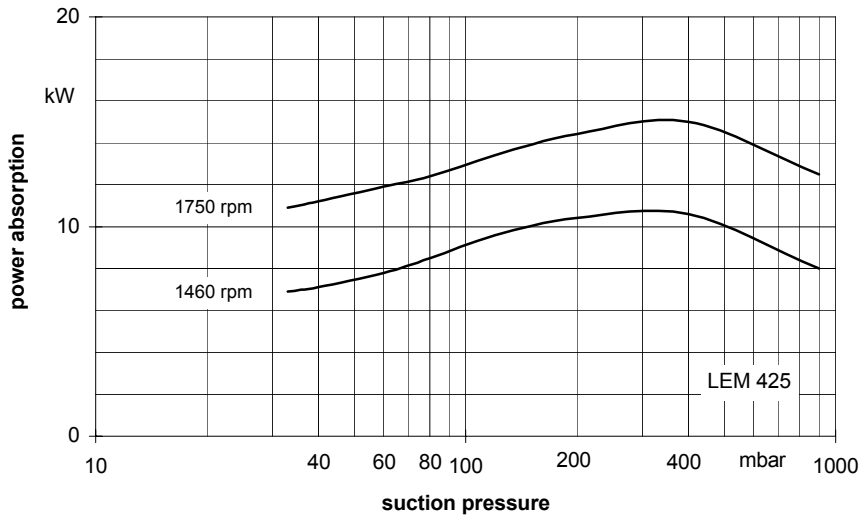
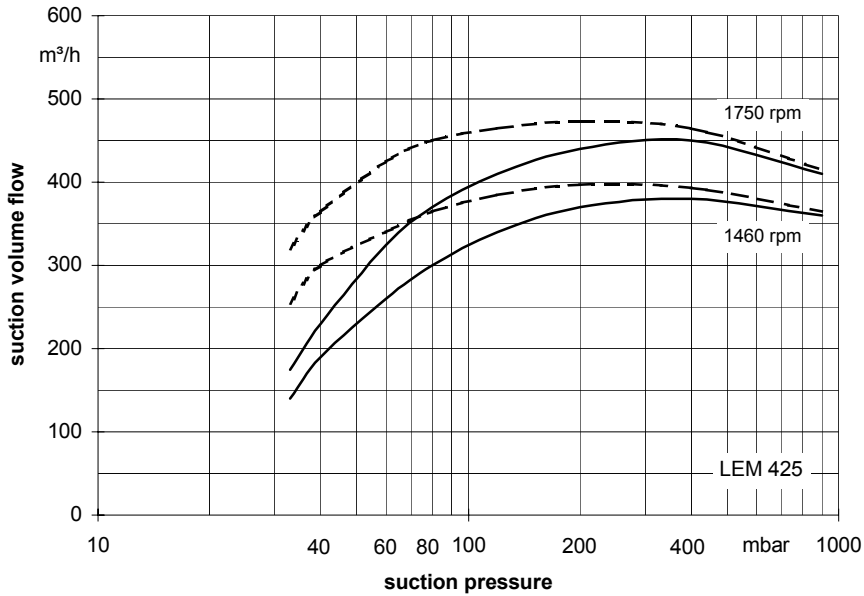

The operating data are applicable under the following conditions:

- pumping medium:
 - dry air: 20°C —————
 - water vapour saturated air: 20°C - - - - -
- service liquid:
 - water: 15°C

Compression pressure 1013 mbar (atmospheric pressure)

The suction volume flow is applied to the suction pressure

Tolerance of the operating data 10%

Max. fresh water need with lowest suction pressure

Dimension table LEM 325, LEM 425

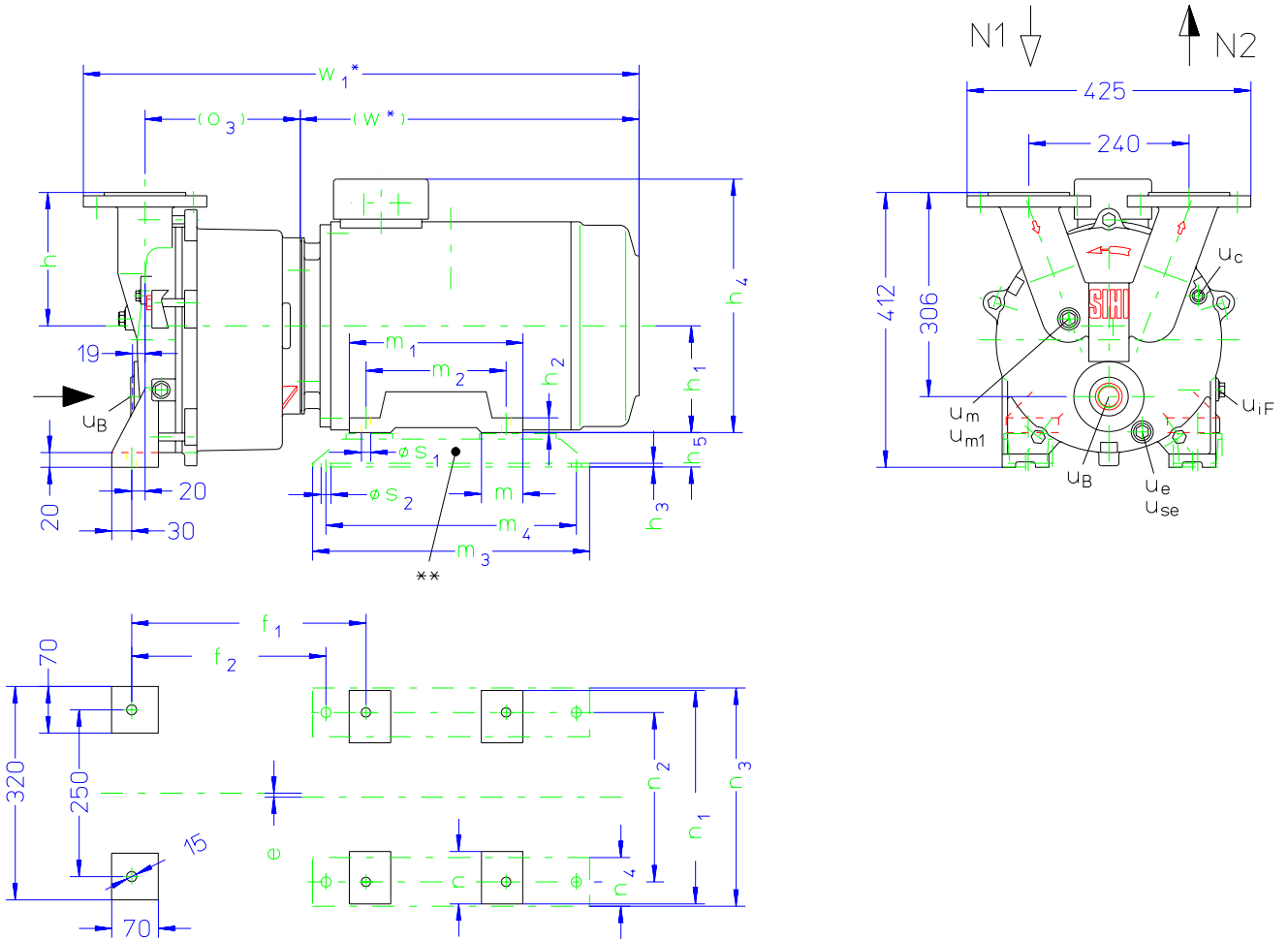

N 1 = gas inlet DN 65

N 2 = gas outlet DN 65

UB = connection for service liquid G 1

UC = connection for protection against cavitation G ¼

Ue = drain connection G ½

Use = connection for dirt drain G ½

Um = connection for pressure gauge G ½

Um = connection for drain valve G ½

Uif = adjusting screw for internal liquid return

	electric motor IP 55		e	f ₁	f ₂	h	h ₁	h ₂	h ₃	h ₄	h ₅	m	m ₁	m ₂	m ₃	m ₄	n	n ₁	n ₂	n ₃	n ₄	O ₃	S ₁	S ₂	w*	w ₁ *	weight abt. kg	
	size	kW																										
LEM 325	132 M	7,5	-	4	315	404	202	132	18	8	320	50	88	218	178	218	0	55	256	216	266	45	219	12	13	393	704	145
	160 M	-	13,2		337	277								260	210												819	185
LEM 425	160 M	11,0	-	6	351	291	200	160	22	6	380	52	62		415	375	69	320	254	319	65	233	14	15	508	833	190	
	160 L	-	18,0											304	254													215

other motors on request

* dimensions dependent on the motor make

** see list of accessories

flange connections see page 6

Arrangement drawing LEM 325, LEM 425

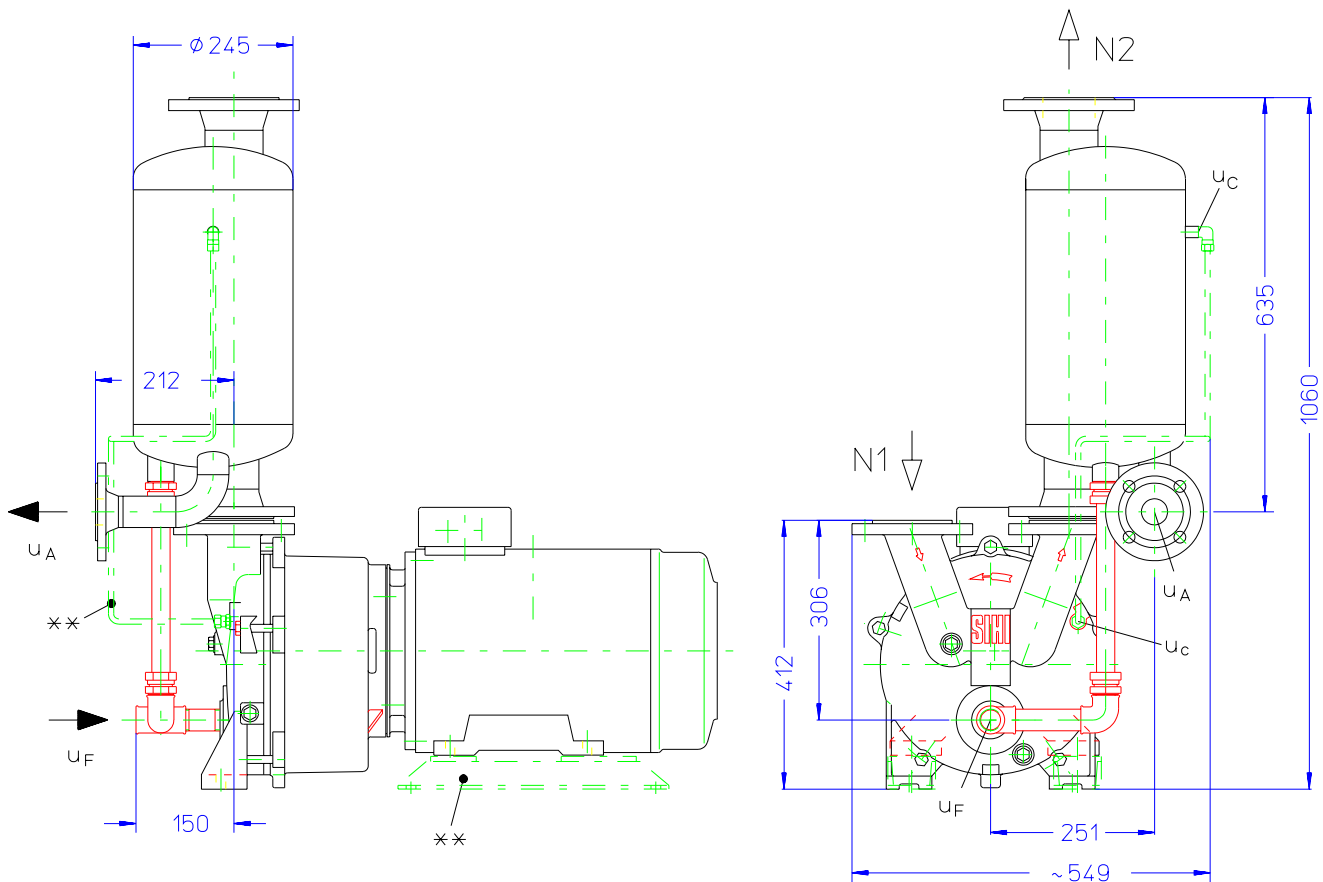

	electric motor IP 55			weight ca. kg
	size	kW		
		50 Hz	60 Hz	
LEM 325	132 M	7,5	-	170
	160 M	-	13,2	210
LEM 425	160 M	11,0	-	215
	160 L	-	18,0	240

other motors on request

** see list of accessories

- N 1 = gas inlet DN 65
- N 2 = gas outlet DN 80
- u_A = connection for DN 40
- u_F = connection for fresh liquid G 1
- u_c = connection for protection against cavitation G 1/4

flange connections to DIN 2501 PN 10			
DN	40	65	80
k	110	145	160
D	150	185	200
number x d_2	4 x 18	4 x 18	8 x 18

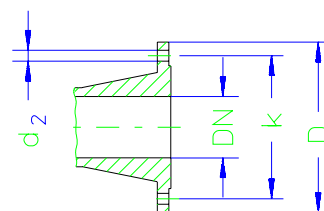

Data regarding the pump size - order notes

series + size	hydraulics + bearings	shaft sealing	material design	casing seal
	<ul style="list-style-type: none"> A• hydraulic A •Z two grease lubricated antifriction bearings arranged in the motor 	<ul style="list-style-type: none"> AAE standard mechanical seal O-rings Perbunan AA1 as AAE, but O-rings Viton 	<ul style="list-style-type: none"> 0B main parts of GG without non-ferrous metal 4B main parts of Cr Ni Mo-cast steel 	0 liquid seal
LEM 325	AZ	AAE, AA1	0B, 4B	0
LEM 425				

Motor selection table

	Y-voltage V +/- 5%	motor enclosure IP 55 50 Hz				motor enclosure IP 55 60 Hz				
		Δ -voltage V +/- 5%	power kW	size	motor- design.	Y-voltage V +/- 5%	Δ -voltage V +/- 5%	power kW	size	motor- design.
LEM 325	660-725	380-420	7,5	132 M	PB	---	440-480	13,2	160 M	TW
LEM 425	---	380-420	11,0	160 M	JW	---	440-480	18,0	160 L	KW

Example for ordering:

The construction size LEM 325 AZ AAE 0B 0 with 7,5 kW three-phase ac motor (50 Hz, 400 V Δ) 1450 rpm has the complete order number:

LEM• 325 AZ AAE 0B 0 PB

If motors with other voltage or frequency are required a special information should be given.

On delivery the point (•) in the fourth place of the type cope is replaced by a letter in the factory.

Accessories LEM 325, LEM 425

Recommended accessories			LEM 325	LEM 425
Overhead liquid separator		type	XBa 2040	
material design	130 / galvanized	weight	20 kg	
	172 / 1.4571	SIHI part No.	35 000 416	
service liquid line			35 000 417	
material design	072 / St 37-0	SIHI part No.	20 055 619	
	172 / 1.4571		20 037 106	
cavitation protection line				
material design	072 / St 37-0	SIHI part No.	20 027 915	
	172 / 1.4571		20 027 916	
Upright liquid separator		type		
material design	130 / galvanized	weight		
	172 / 1.4571	SIHI part No.		
service liquid line				
material design	072 / St 37-0	SIHI part No.	on request	
	172 / 1.4571			
discharge line (bend)				
material design	072 / St 37-0	SIHI part No.		
	172 / 1.4571			
cavitation protection line				
material design	072 / St 37-0	SIHI part No.		
	172 / 1.4571			
SIHI-gas ejector				
at service liquid temperature		15 °C	GEV 325 A	GEV 425 A
at service liquid temperature		30 °C	GEV 325 B	GEV 425 B
SIHI-ball type non-return valve		type	XCk 65	
material design	767 / GG-25	weight	5,6 resp. 15,8 kg	
	784 / 1.4408	SIHI part No.	20 072 794	
			20 029 500	
Support food				
for motor size 132 M		SIHI part No.	20 047 013	-
for motor size 160 M, 160 L			20 047 014	20 047 015

Any changes in the interest of the technical development are reserved.

Sterling SIHI GmbH

Lindenstraße 170, D-25524 Itzehoe, Germany, Telephone +49 (0) 48 21 / 7 71-01 , Fax +49 (0) 48 21 / 7 71-274